

# ergotron®

## StyleView Sit Stand Combo System with Small CPU Holder

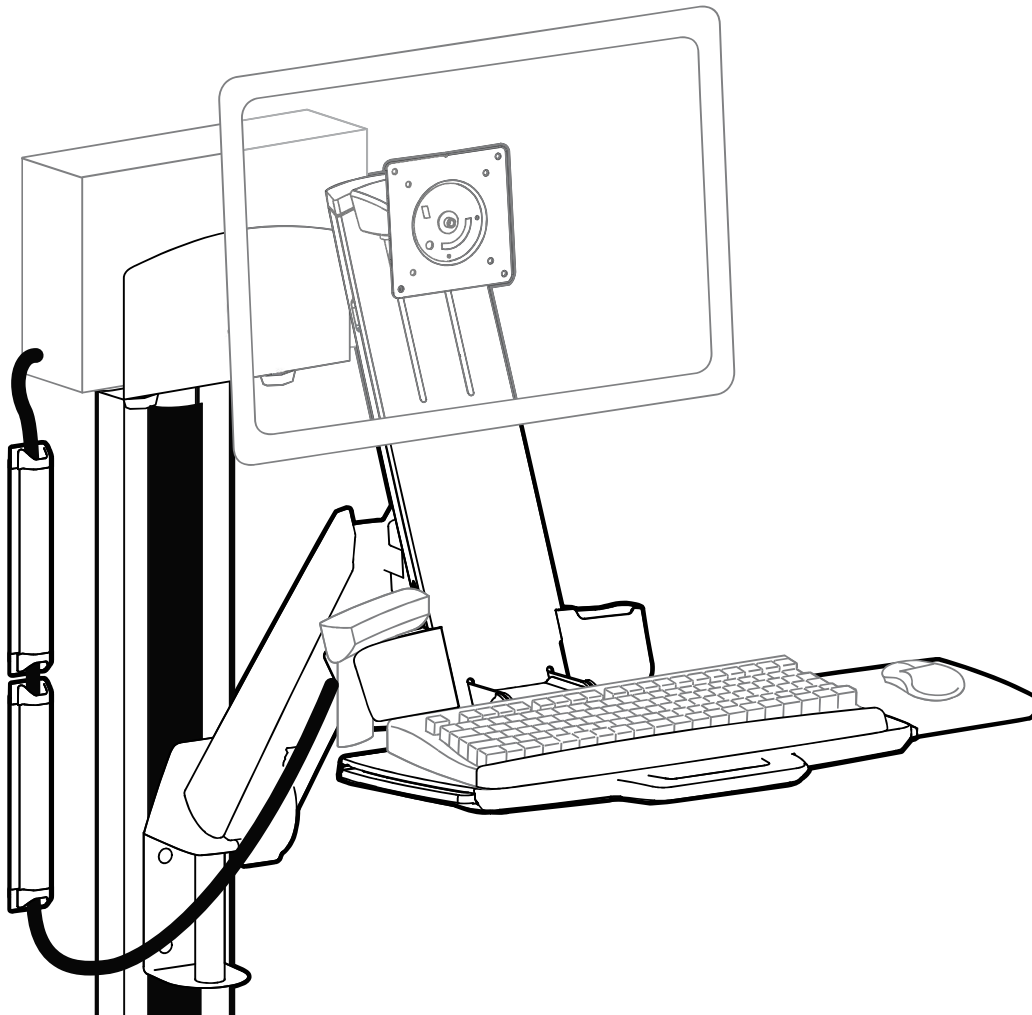

English



For the latest User Installation Guide please visit: [www.ergotron.com](http://www.ergotron.com)

English, Español, Français, Deutsch, Nederlands, Italiano, Svenska, 日本語, 汉语

[www.ergotron.com](http://www.ergotron.com) | USA: 1-800-888-8458 | Europe: +31 (0)33-45 45 600 | China: 400-120-3051 | Japan: [japansupport@ergotron.com](mailto:japansupport@ergotron.com)



Important! You will need to adjust this product after installation is complete. Make sure all your equipment is properly installed on the product before attempting adjustments. This product should move smoothly and easily through the full range of motion and stay where you set it. If movements are too easy or difficult or if product does not stay in desired positions, follow the adjustment instructions to create smooth and easy movements. Depending on your product and the adjustment, it may take many turns to notice a difference. Any time equipment is added or removed from this product, resulting in a change in the weight of the mounted load, you should repeat these adjustment steps to ensure safe and optimum operation.

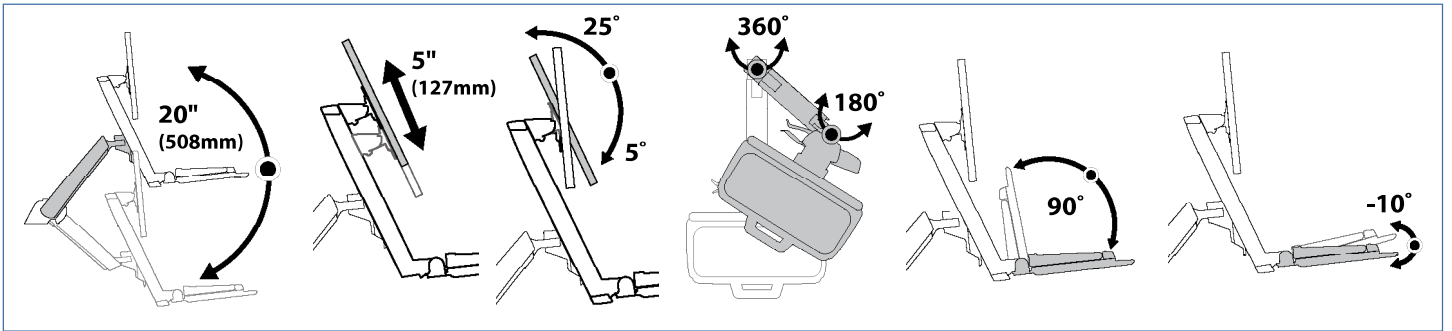
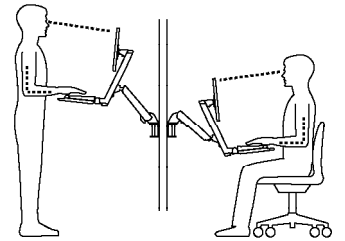
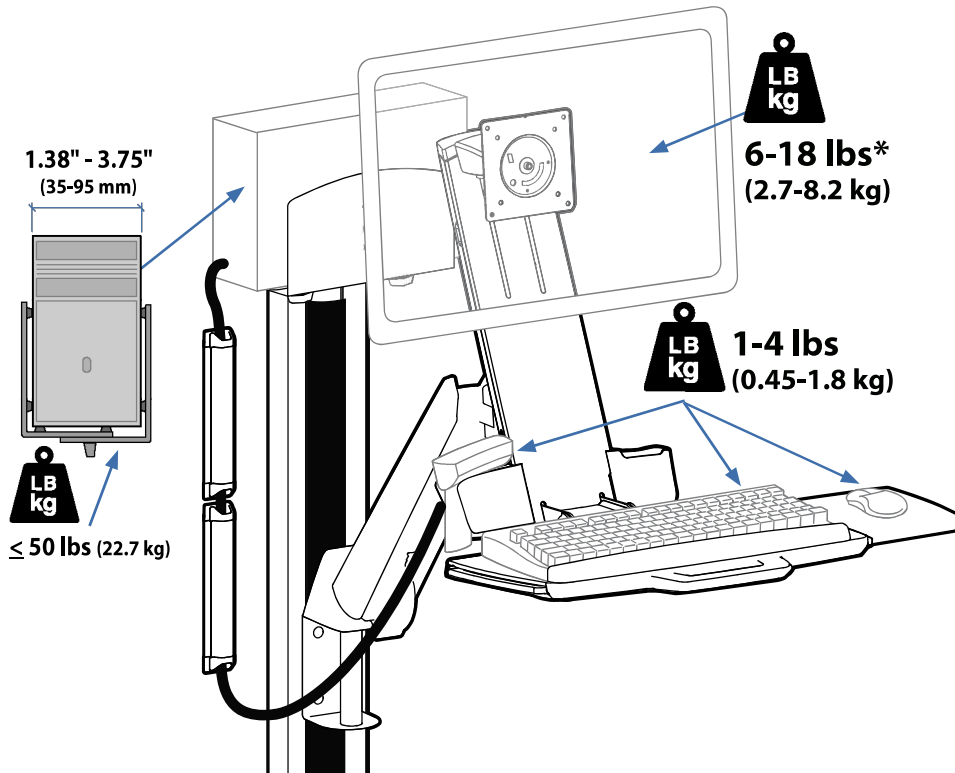

## Tools Needed

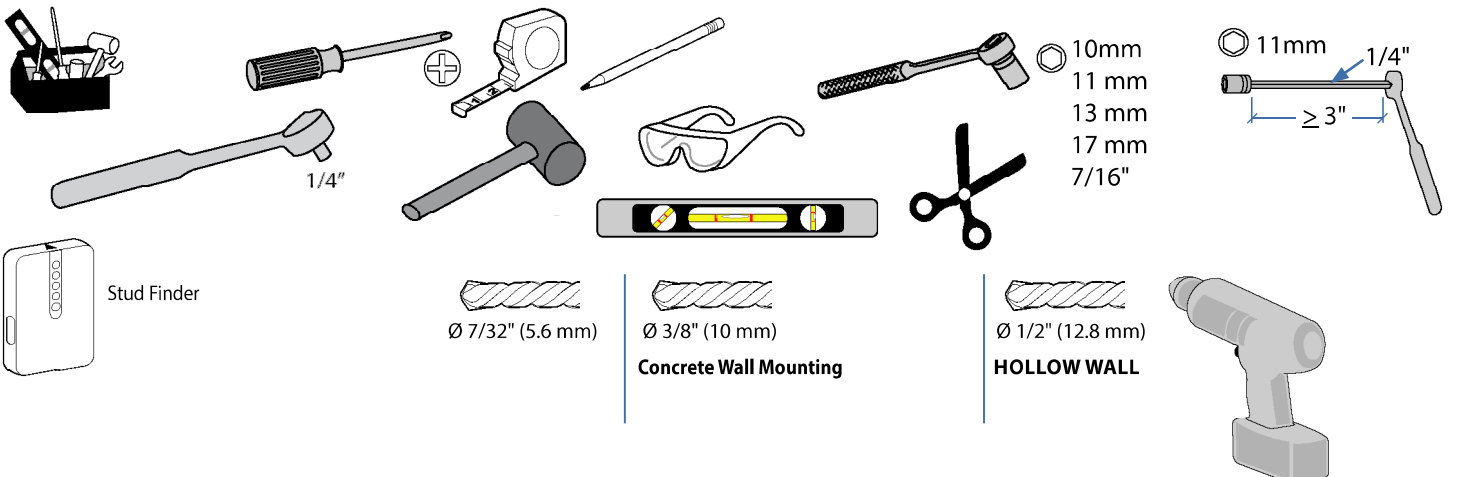

# Components



	A	B	C	D	E
1	1x 	2x 	1x 	1x 	2x 
2		2x 	1x 	1x 	3x 
3		2x 	1x 	7x 	2x 
4		1x 	1x 	4x 	2x 
		1x 	1x 	1x 	
		1x 	1x 		
		1x 		1x 	8x 
5	4x 	10x 	4x 	1x 	4x 
6	2x 	10x 	10x 		10x 
7	1x 	10x 	1x 	1x 	2x 
8	1x 	4x 	4x 	4x 	2x 
9	1x 	2x 	Optional Weight Capacity Modification Fasteners		

# 1 Mounting Height for Ergonomic Workstation

This mounting height is a recommendation for an ergonomic workstation that accommodates user heights of 5'3"-5'9" (160-175cm).

If user heights are different than this, you should change mounting height to accommodate user heights. (Change mounting height one inch for every one inch difference in user heights).

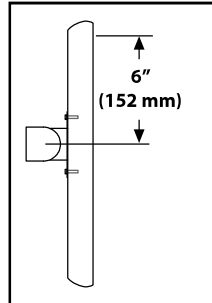
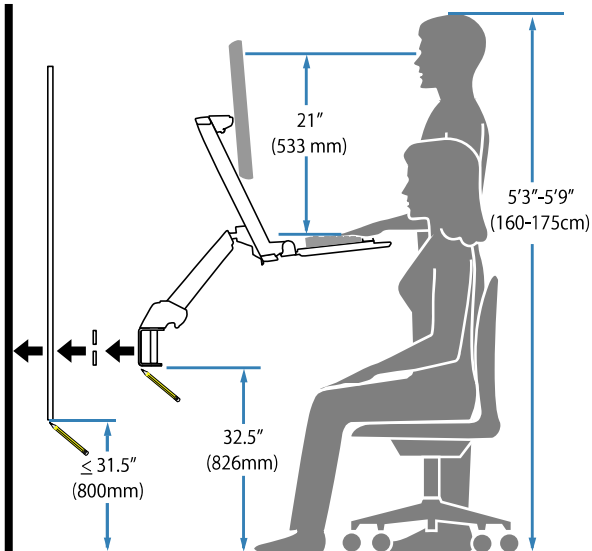

Mounting height assumes there is a 6" (152 mm) distance between the center of your monitor mounting holes and the top of the screen. If your distance is smaller, you should increase mounting height accordingly, if your distance is larger, you should decrease your mounting height accordingly.

## Determine mounting location:

Front view with arm pushed back against the wall.

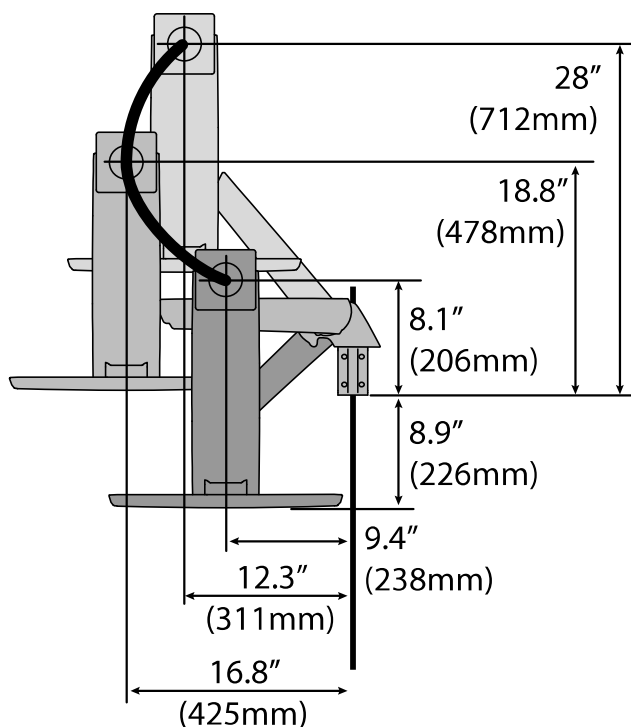

Top view showing range of motion when pulled out from the wall.

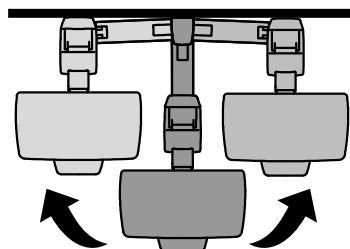

# 2

## Concrete Wall Mounting

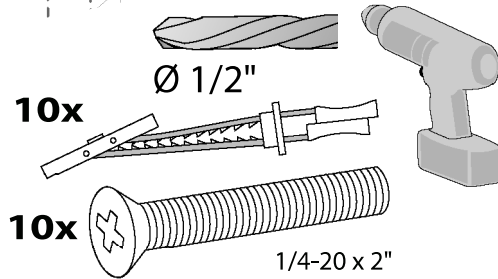
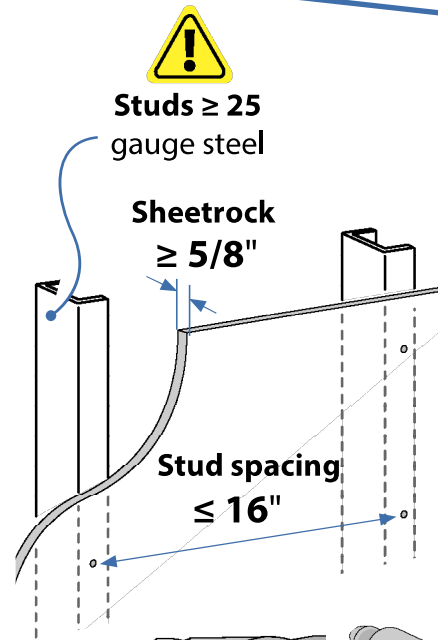
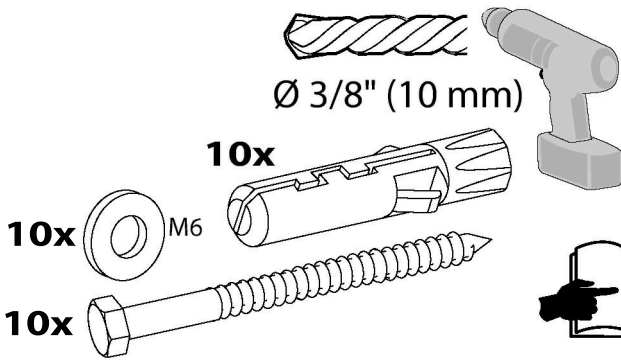
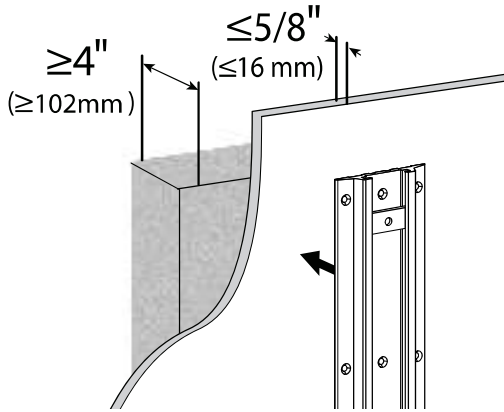

**WARNING:** Because surfaces vary widely and the ultimate mounting method is out of Ergotron's control, it is imperative that you consult with appropriate engineering, architectural or construction professional to ensure that your Ergotron mounting solution is mounted properly to handle applied loads.

## 2 Concrete Wall Mounting

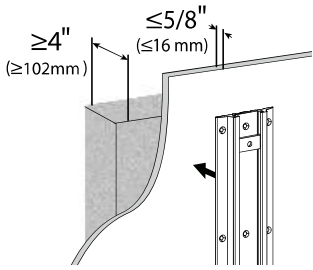

**WARNING:**

Mounting holes must be at least 3-1/8" (80mm) deep and must be located within solid concrete, not mortar or covering material. If you drill into an area of concrete that is not solid, reposition mounting holes until both anchors can be fully inserted into solid concrete!

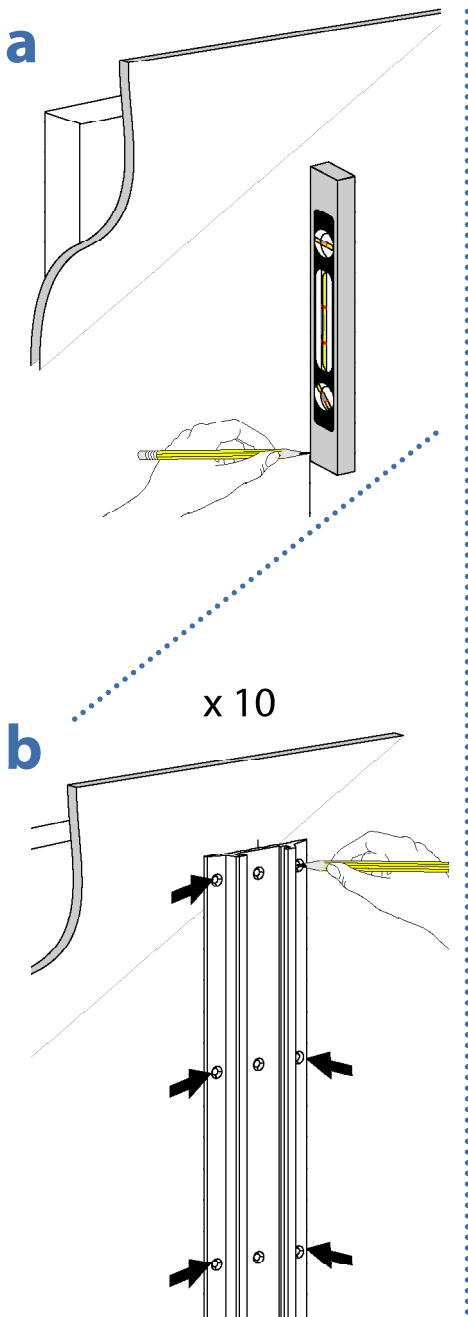

**c**

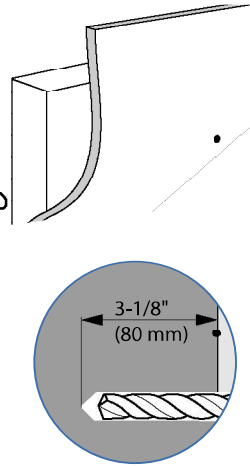

Ø 10mm

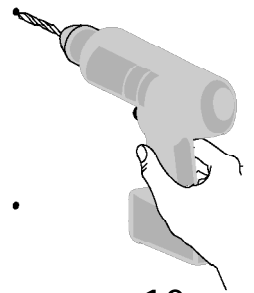

x 10



**WARNING:**

Anchors that are not fully set in solid concrete will not support the applied load resulting in an unstable, unsafe condition which could lead to personal injury and/or property damage. Consult a construction professional if you have any doubt about what this means in regard to your particular situation.

d

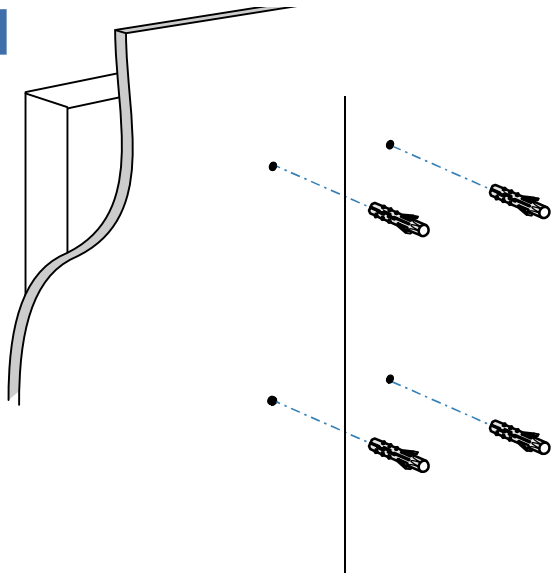

10x

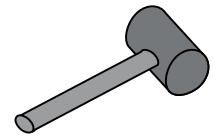
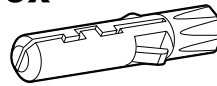

1

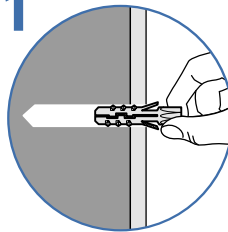

2

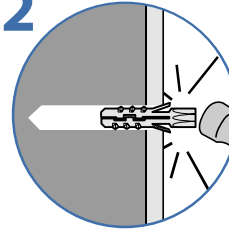

3

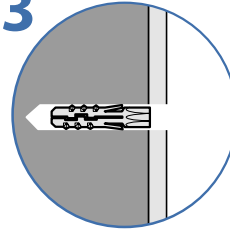

e



10x

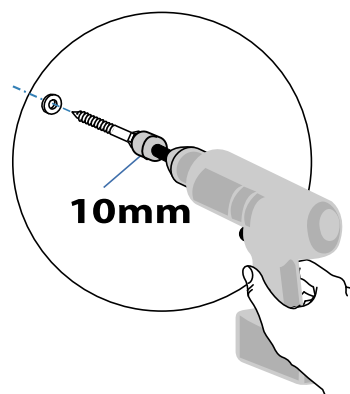
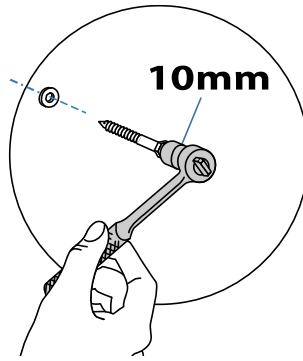
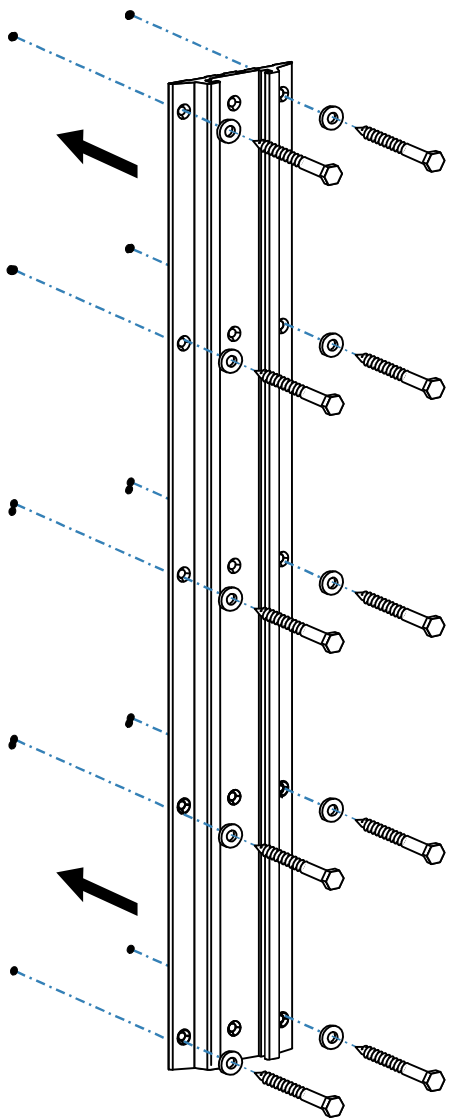
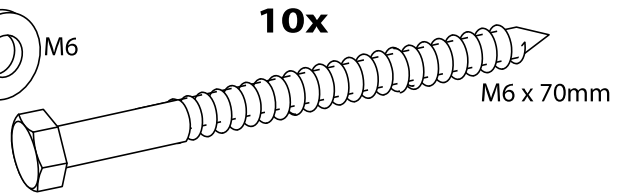

**CAUTION:** Make sure the wall mount bracket is level, flush and snug to the wall surface. **DO NOT OVERTIGHTEN THE BOLTS.**

## 2 HOLLOW WALL

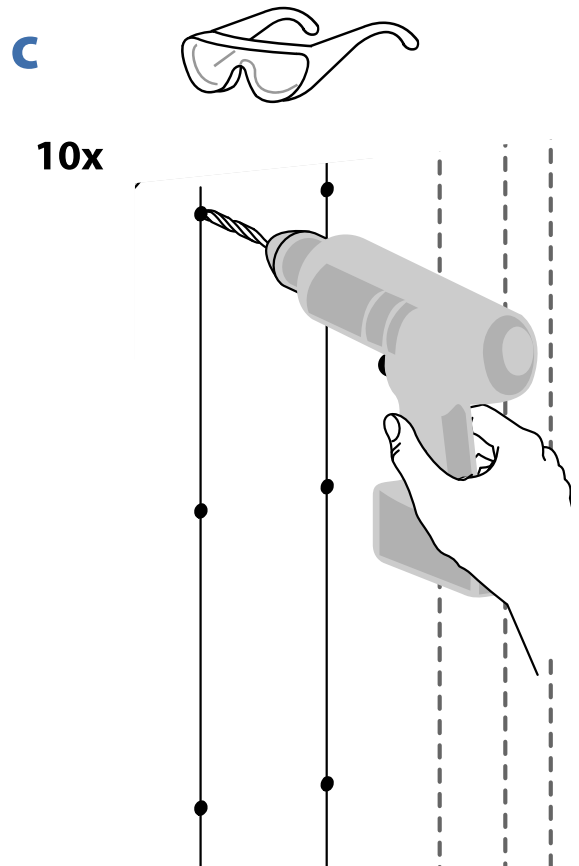
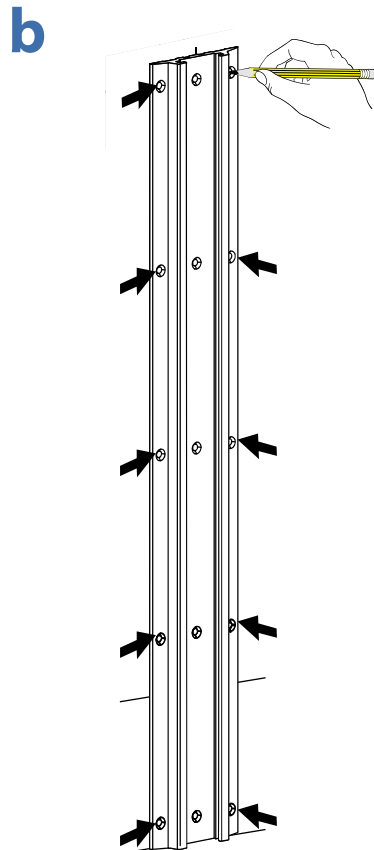
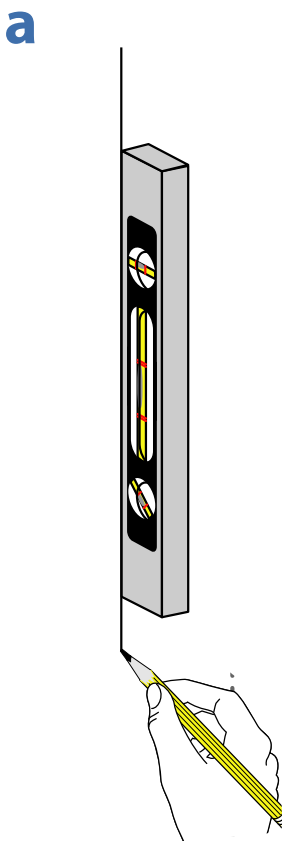
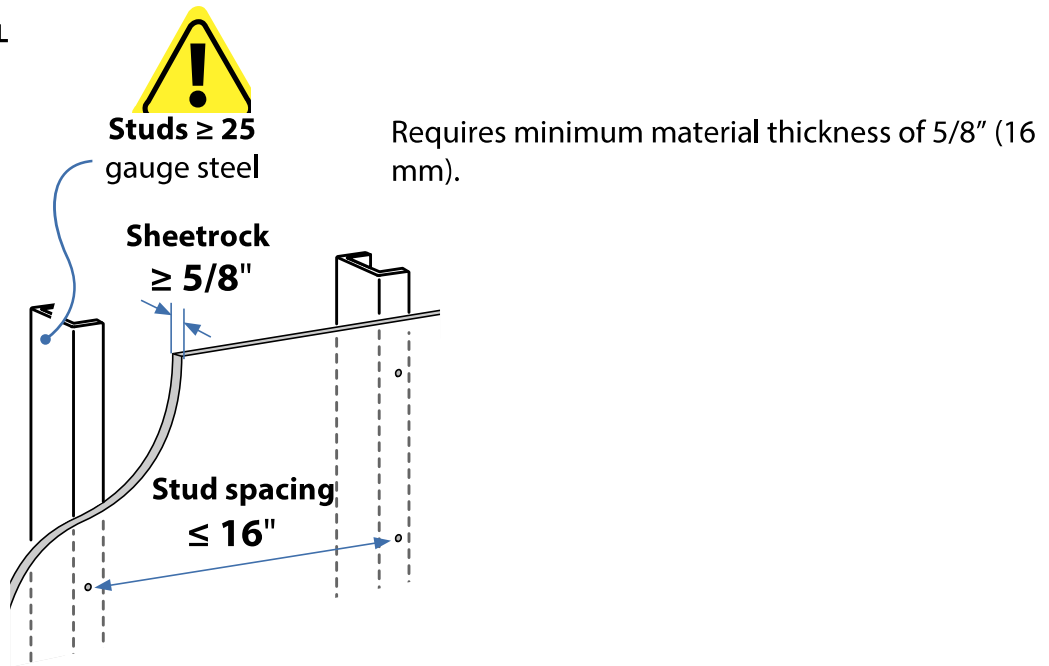

# 2 HOLLOW WALL

d

10x

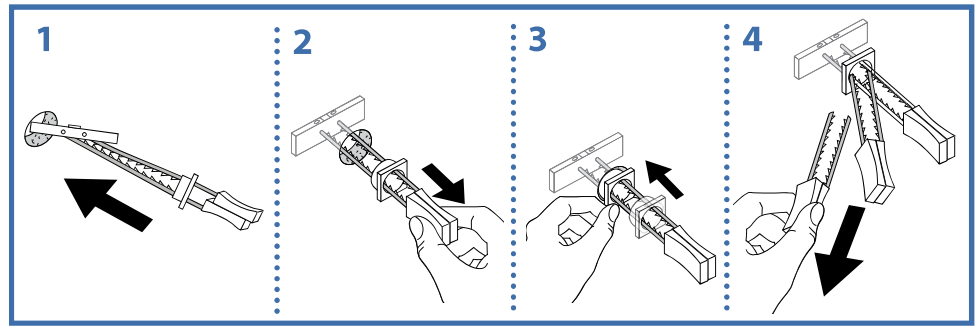
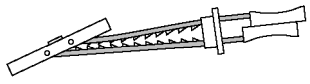

e

10x

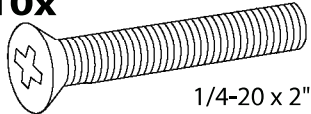

1/4-20 x 2"

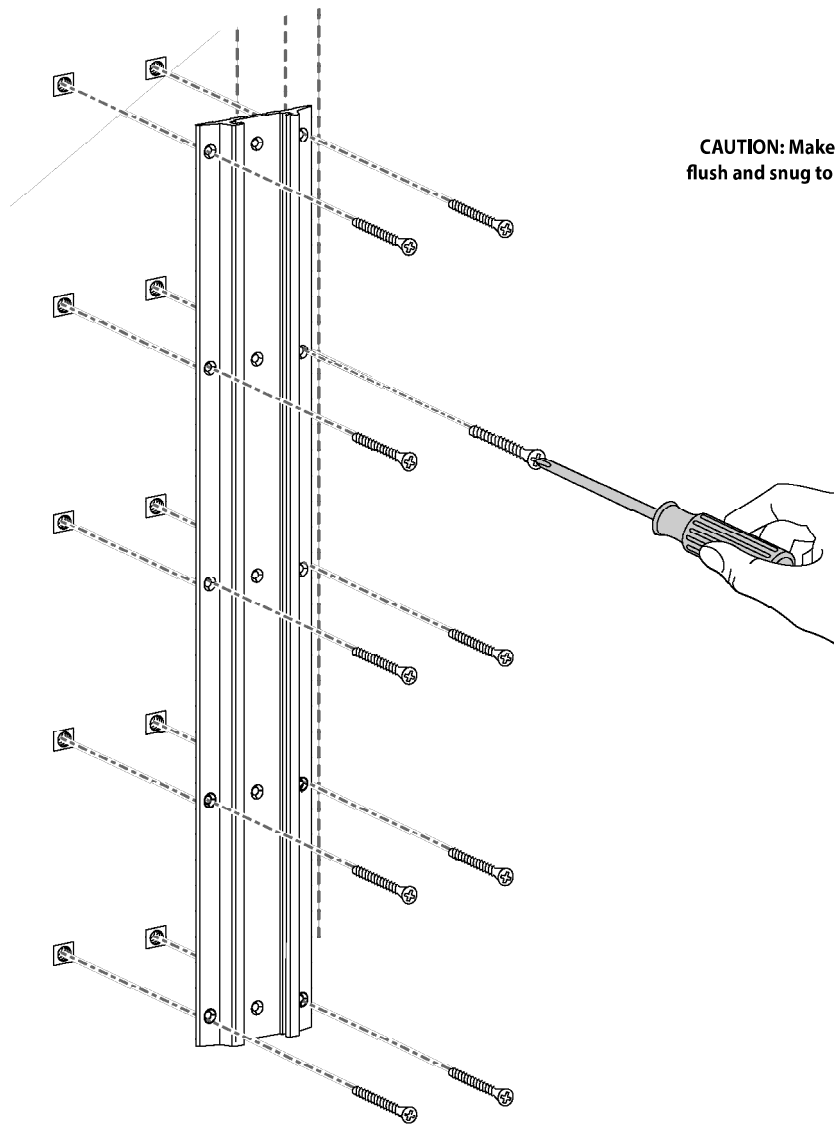

**CAUTION:** Make sure the wall mount bracket is level, flush and snug to the wall surface. **DO NOT OVERTIGHTEN THE BOLTS.**



3 a

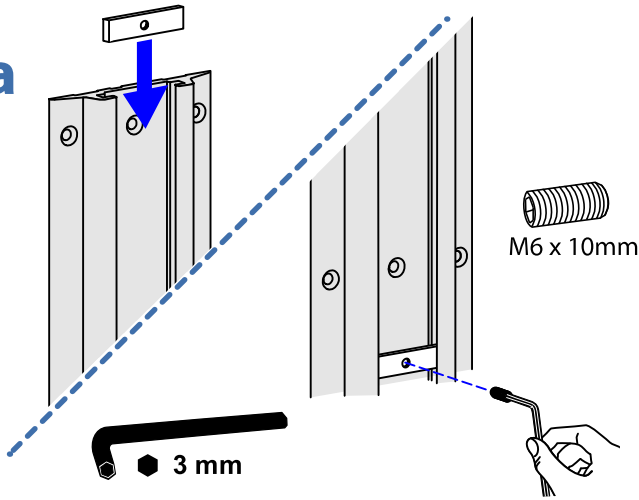

b

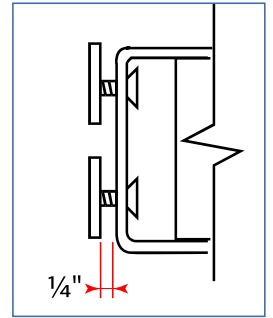
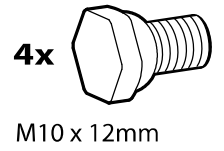
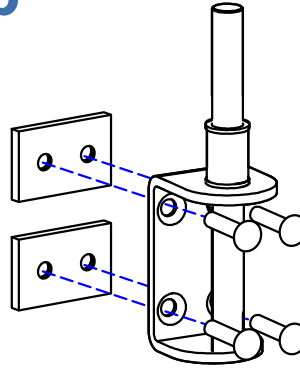

c

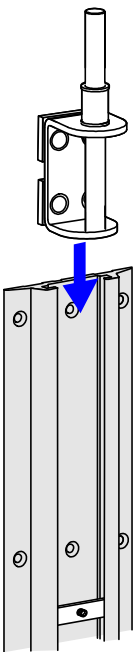

d

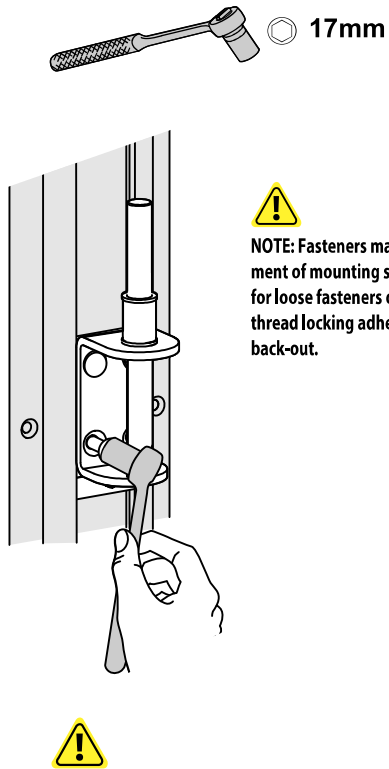

**NOTE:** Fasteners may unwind due to vibration caused by movement of mounting solution over time. Inspect mounting solution for loose fasteners on a routine basis. If desired, apply a light duty thread locking adhesive to fasteners before installation to prevent back-out.



4 a

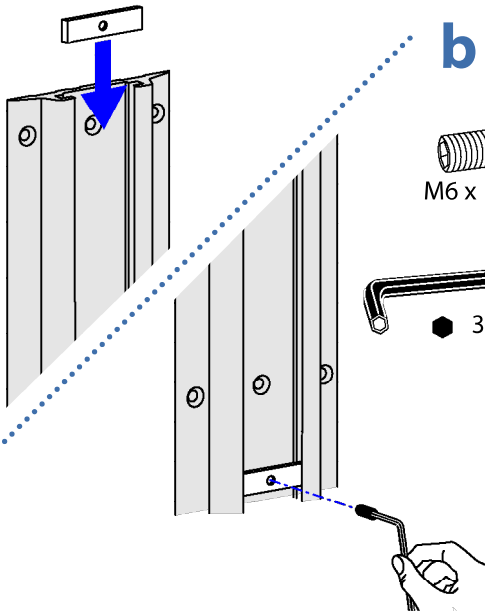

b

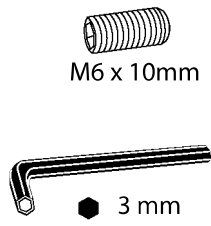

c

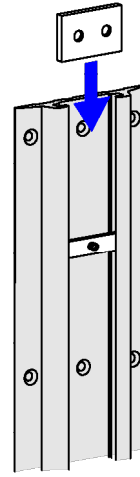

d

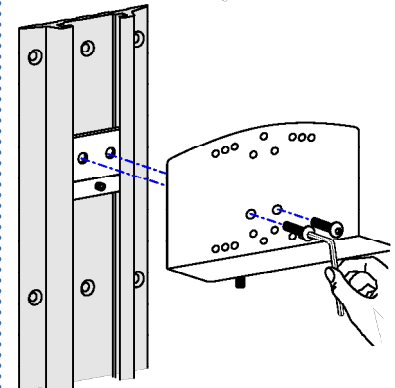
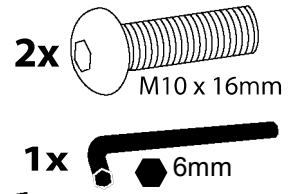

e

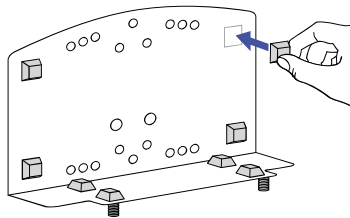
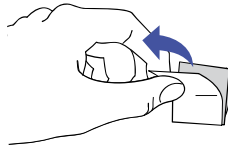

f

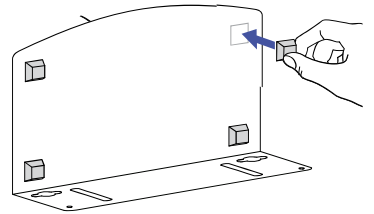

g

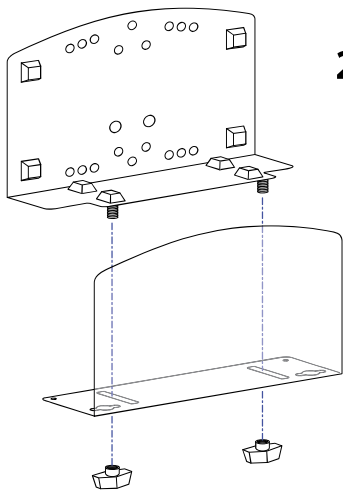

h

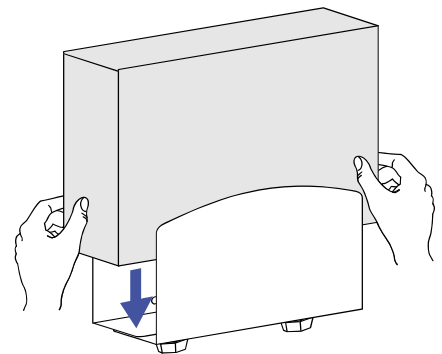

i

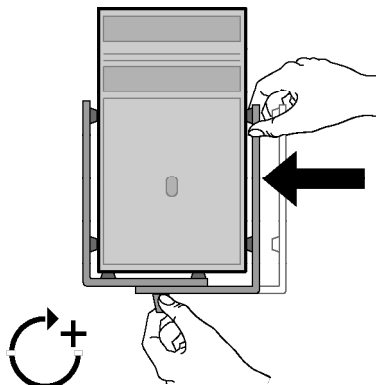

5

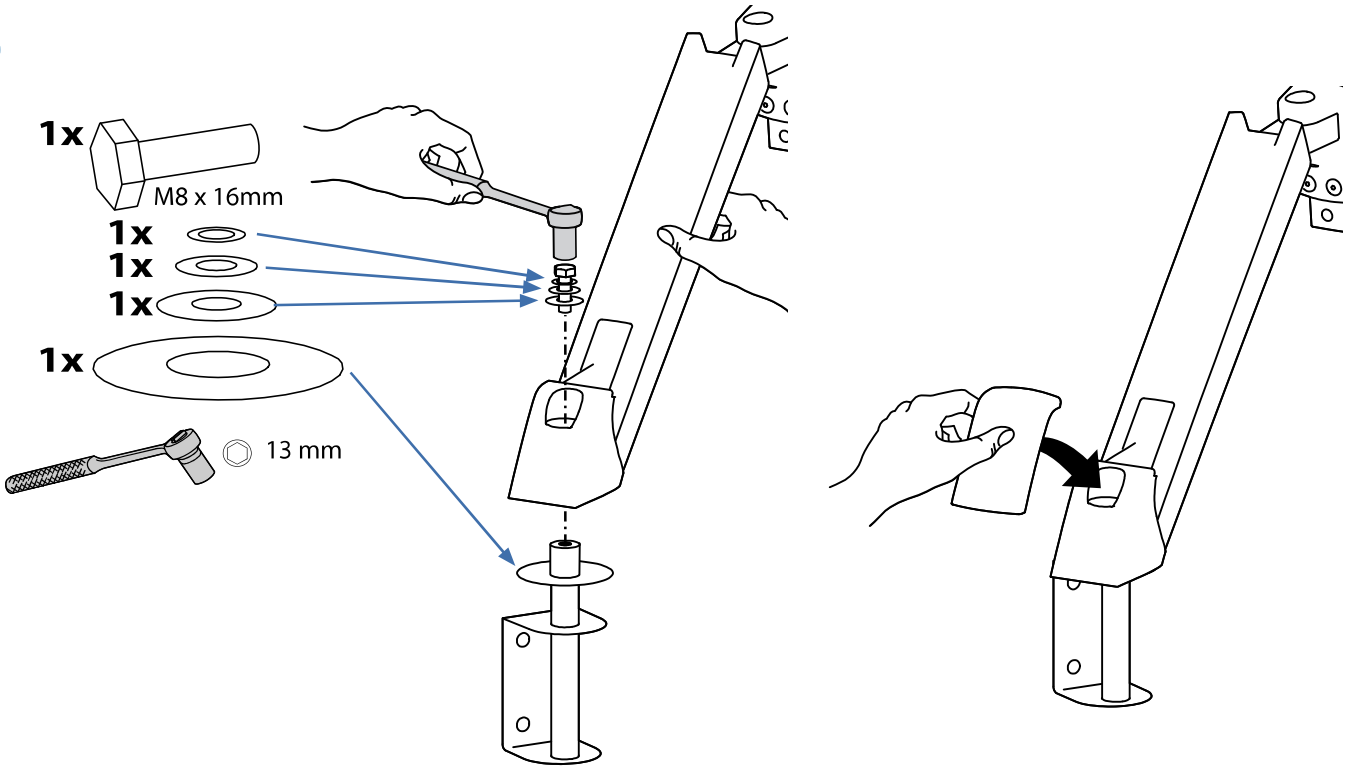

6

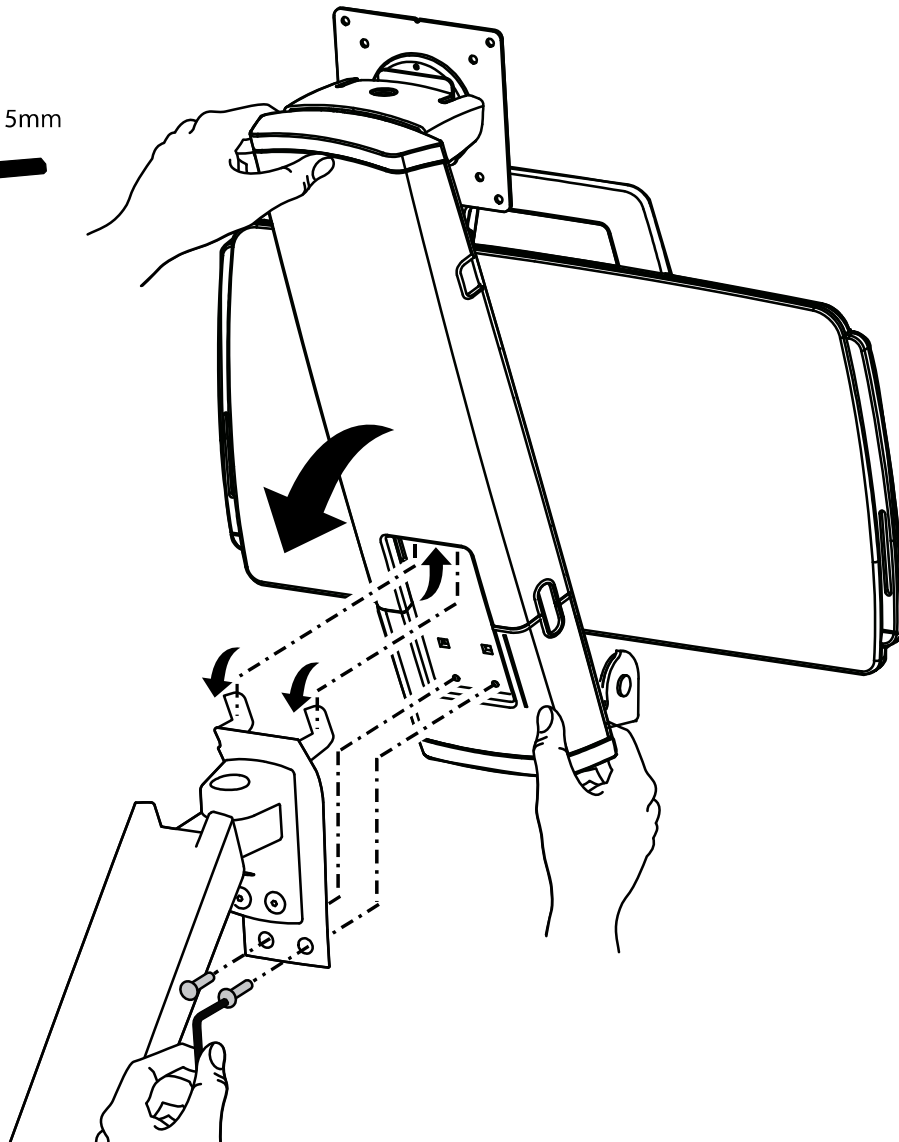
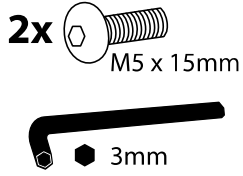

**7 a**

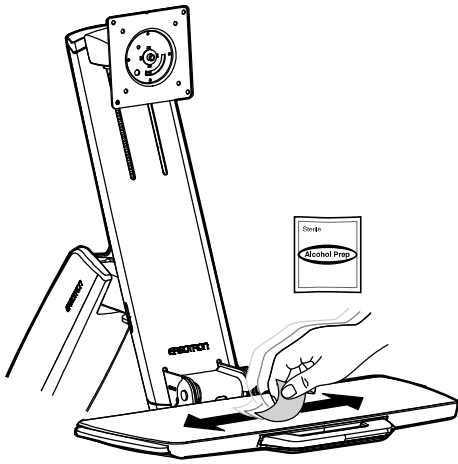

**b**

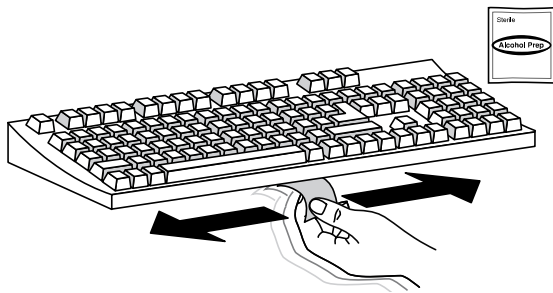

**c**

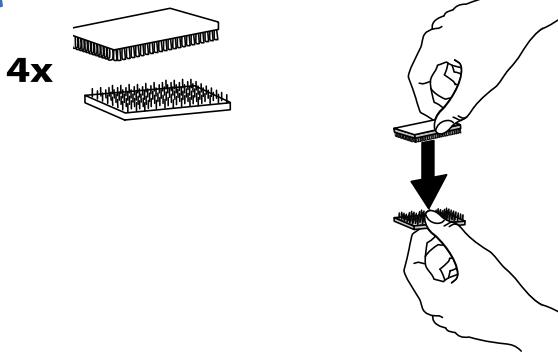

**d**



**e**

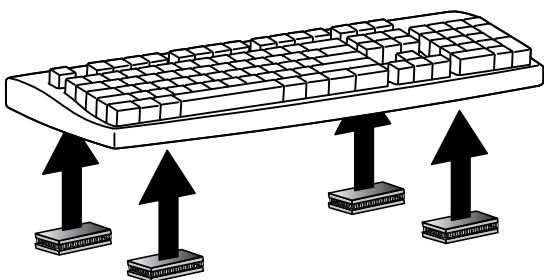

**f**

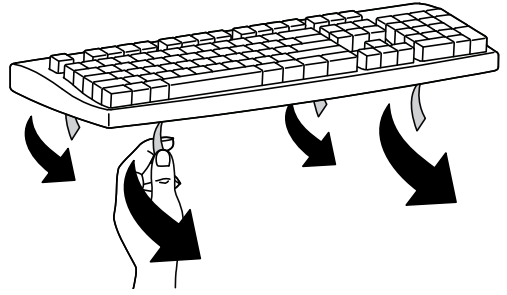

**g**

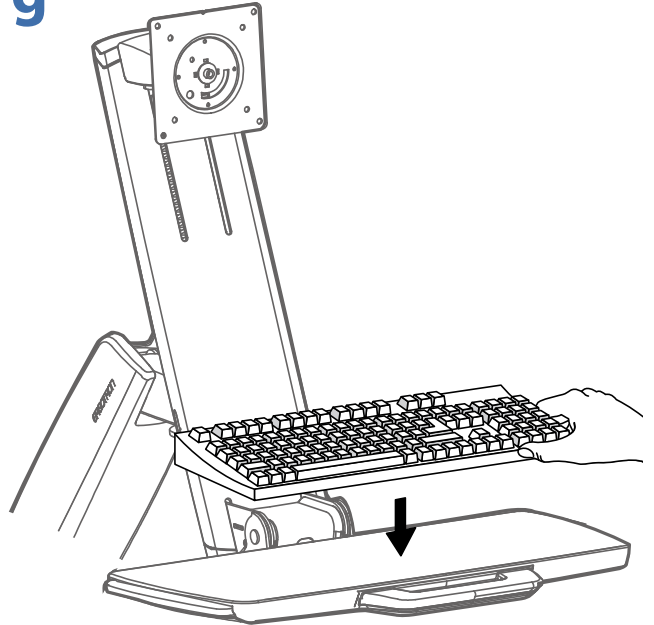

**h**

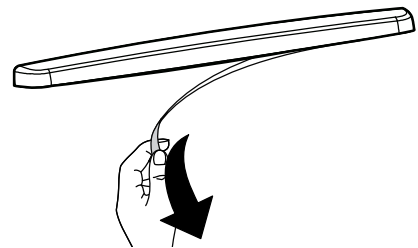

**i**

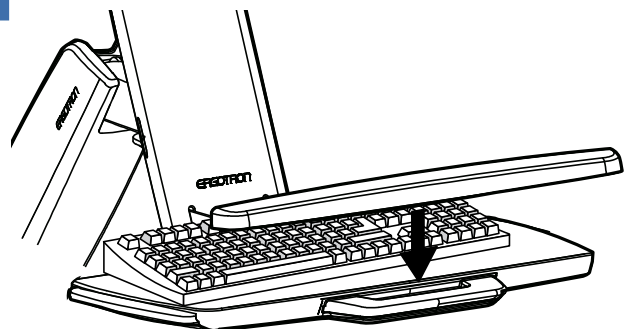

# Optional Weight Capacity Modification

Optional Weight Capacity Modification for Displays 18 - 25 lbs (8.2 - 11.3 kg) Only!

**IMPORTANT:** with this option display lift and tilt motion are no longer possible. To accommodate extra weight, the display is fixed at one of three heights (spaced 2.5" (64 mm) apart), and display tilt is fixed at 20°. If mounting a display 18 lbs (8.2 kg) or less, skip to next page.

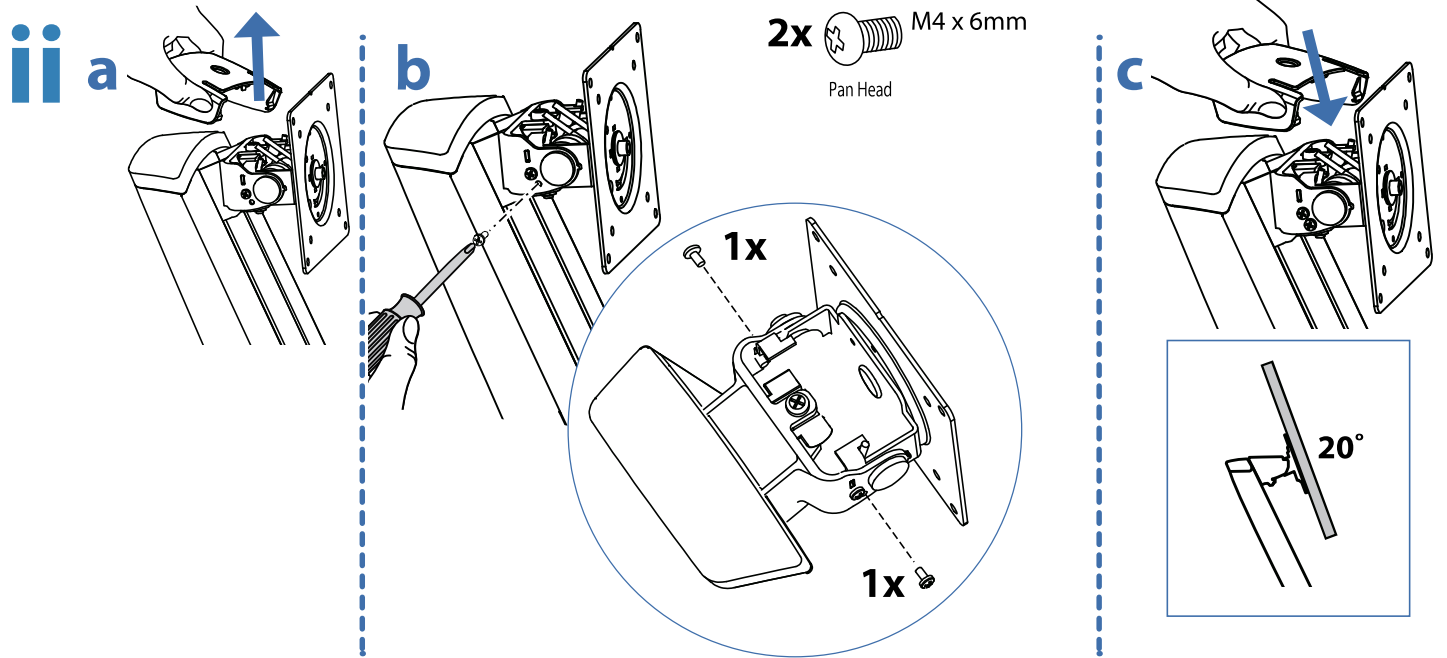
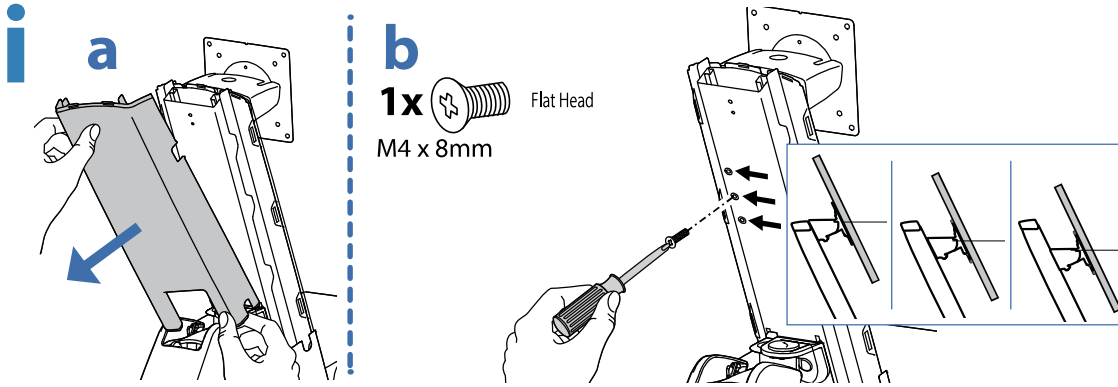

8

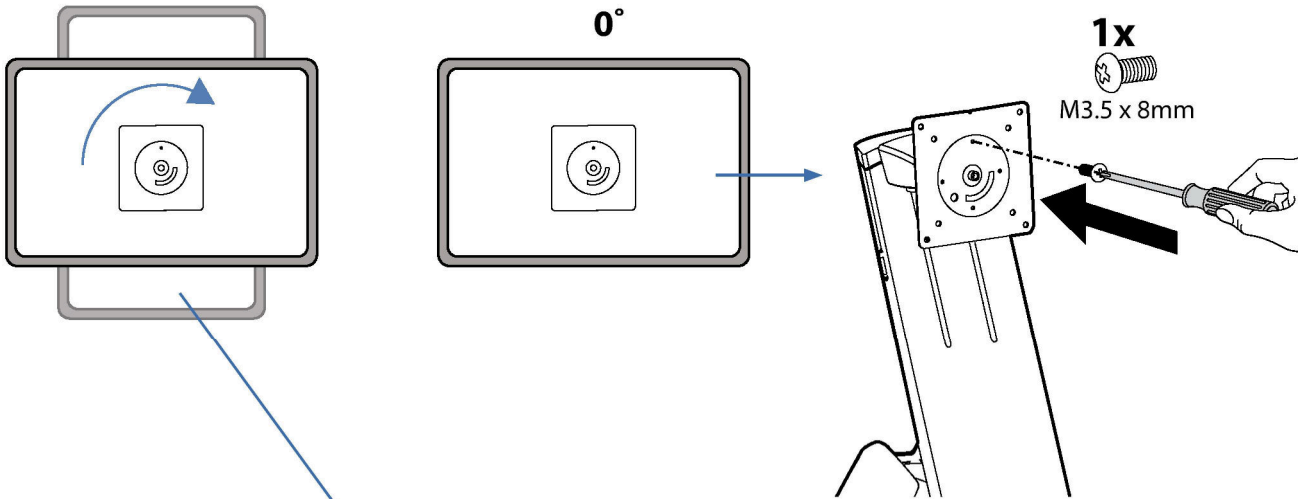

9

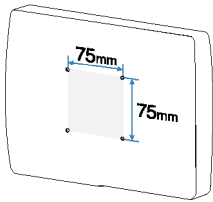

75mm

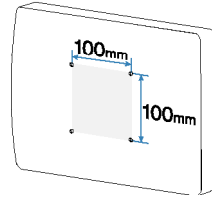

100mm

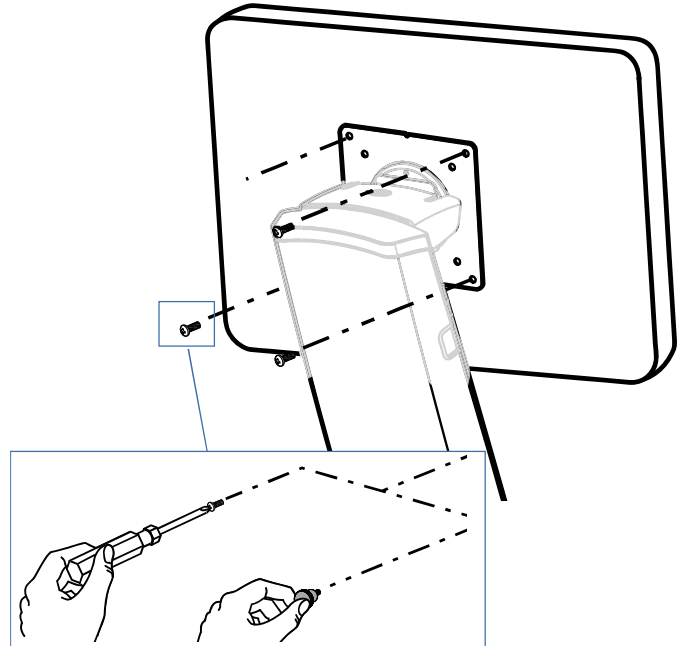
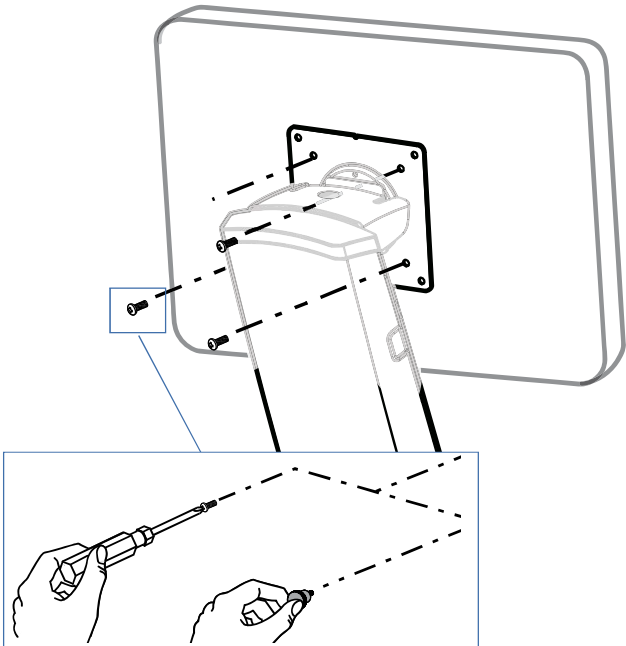
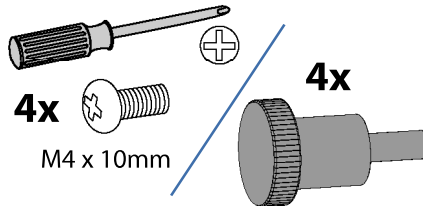

# 10



**NOTE:** Leave enough slack in cable to allow full range of motion.



**Caution:**

To avoid the potential to pinch cables it is important to follow the cable routing instructions in this manual. Failure to follow these instructions may result in equipment damage or personal injury.

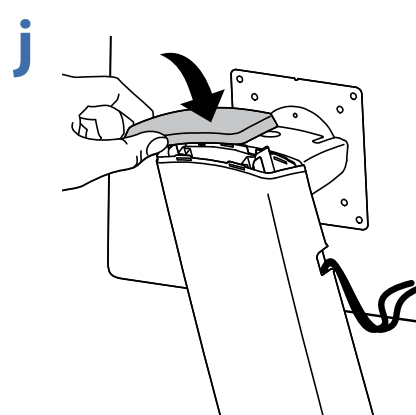
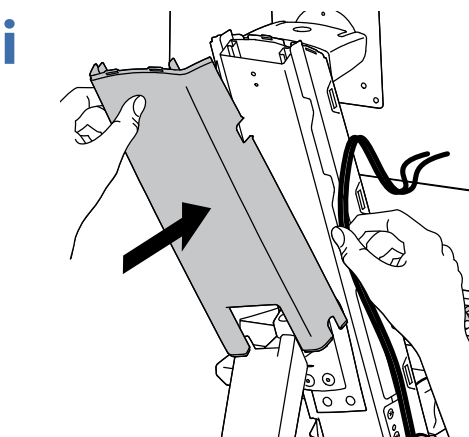
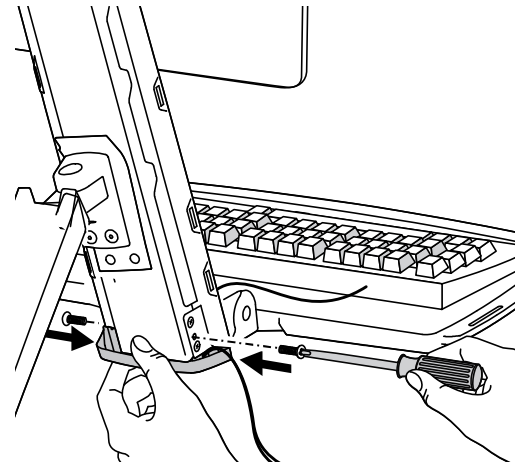
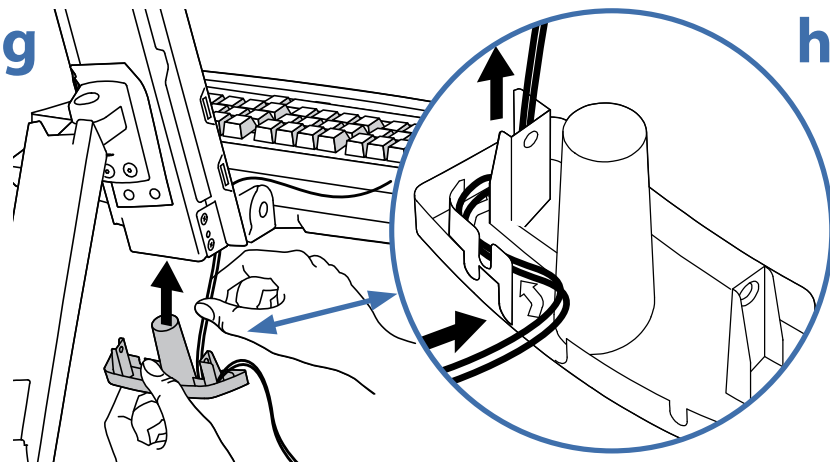
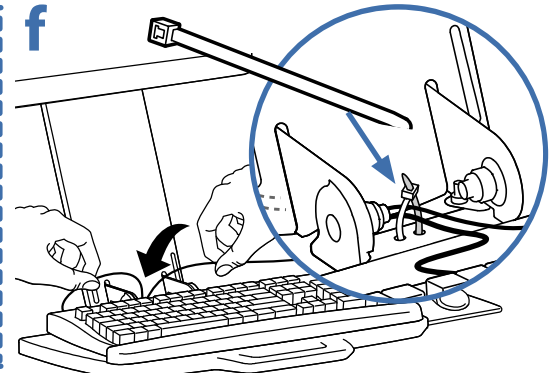
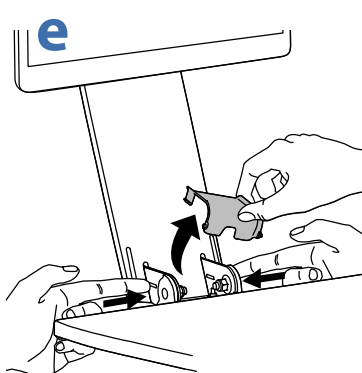
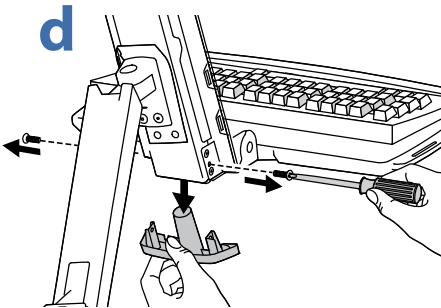
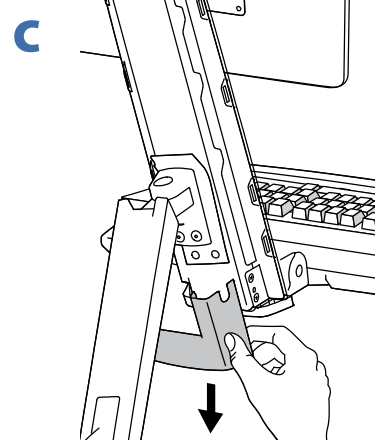
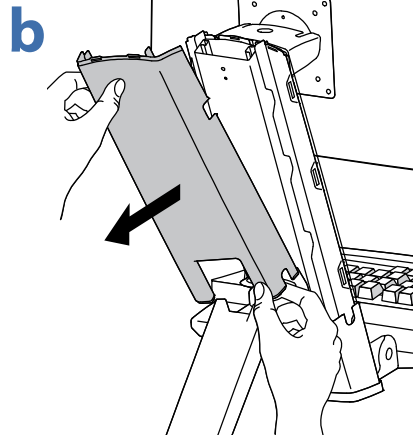
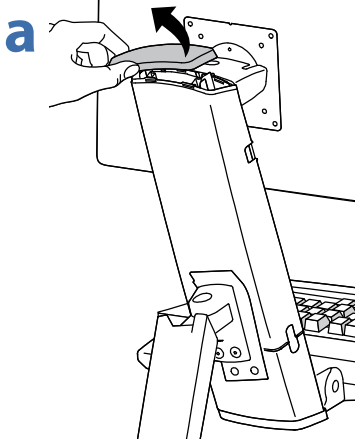

**k**

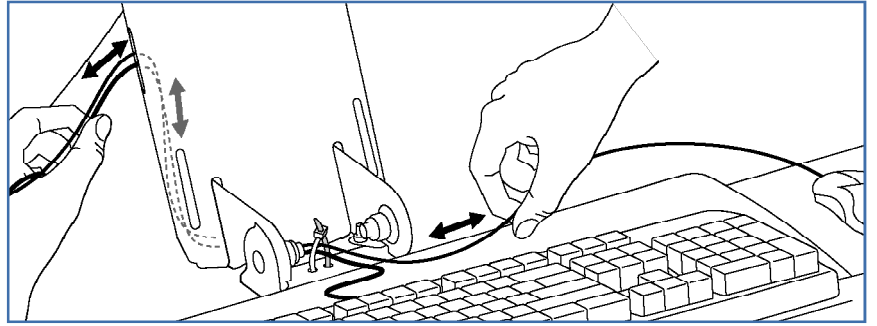
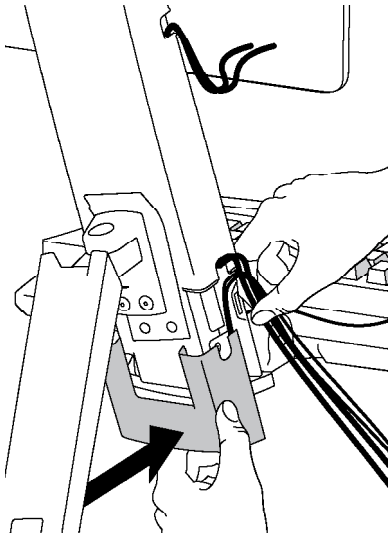



NOTE: Make sure cables can slide in and out through covers and cable channels.

**l**



**m**

- 2x 
- 7x 
- 5x 

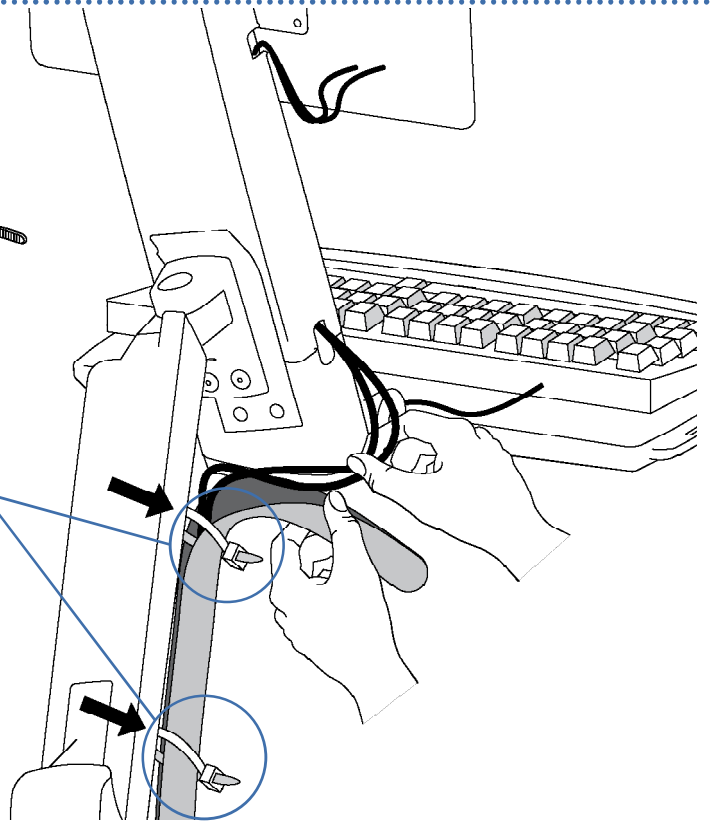
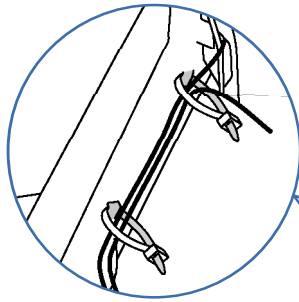

**11**



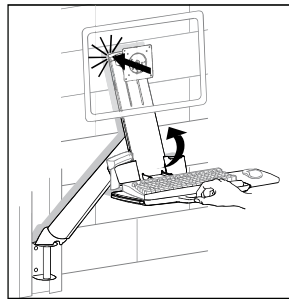
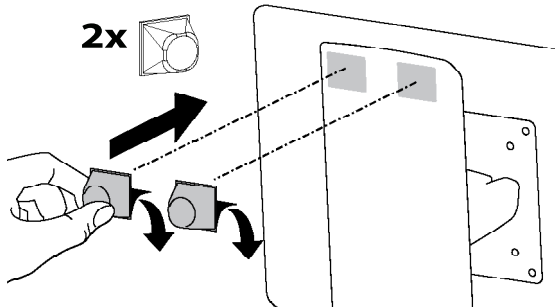

2x 

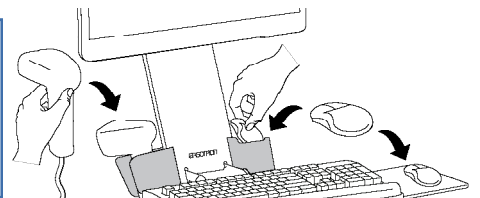
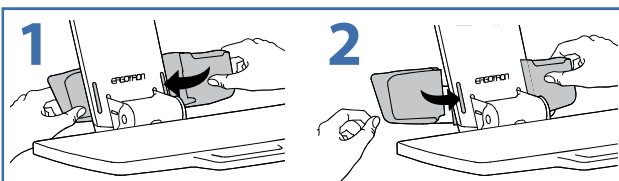
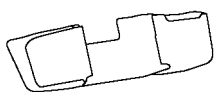

**12**

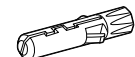

# 13

- 4x  M4.2 x 25mm
- 4x 
- 2x 
- 2x 
- 2x  Ø 7/32" (xx mm)  
.21875
- 2x 



CAUTION: Make sure there is enough clearance between back of mounted component and cable channel. Failure to allow clearance space may result in personal injury and equipment damage.

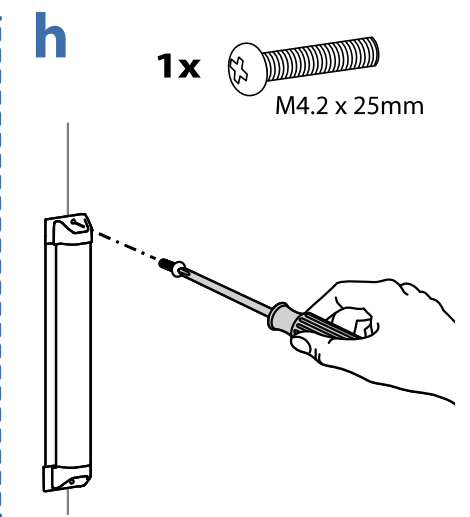
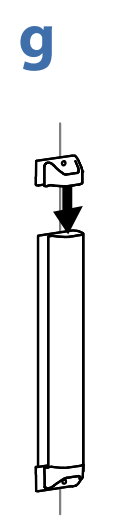
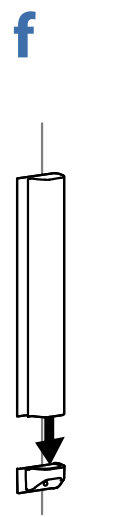
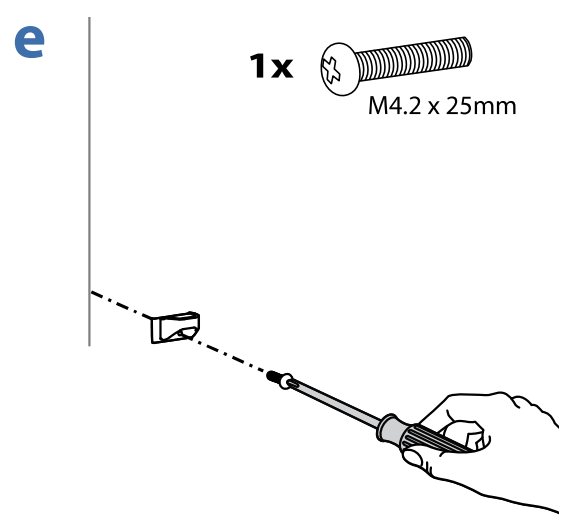
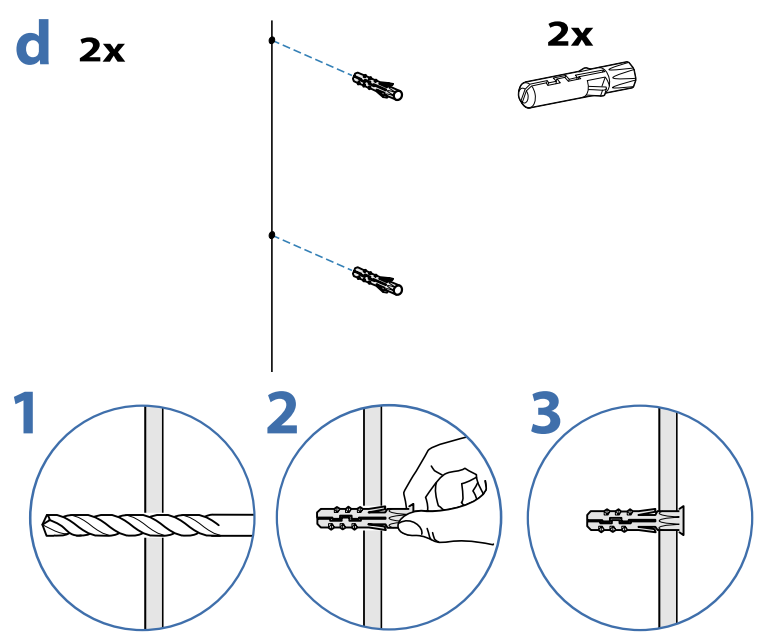
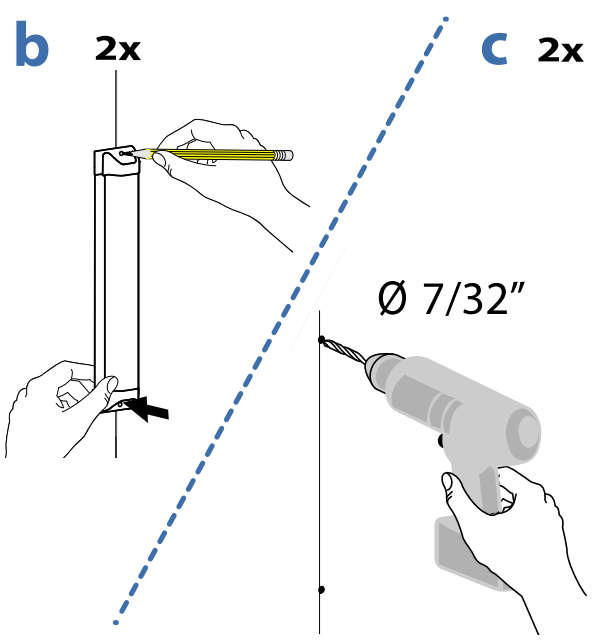
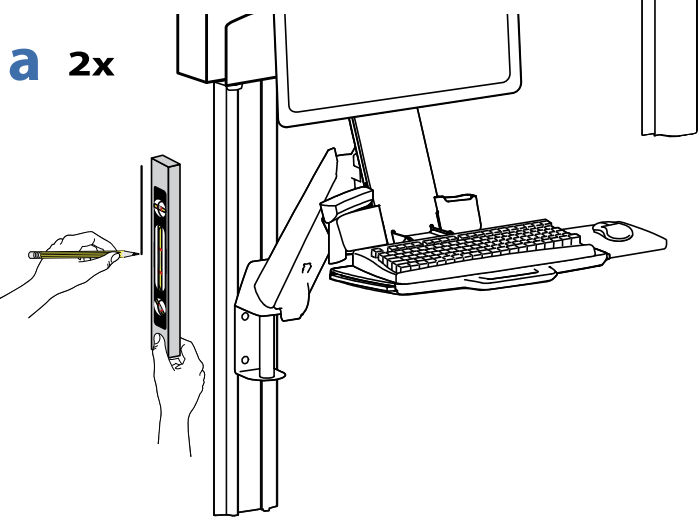

**i**

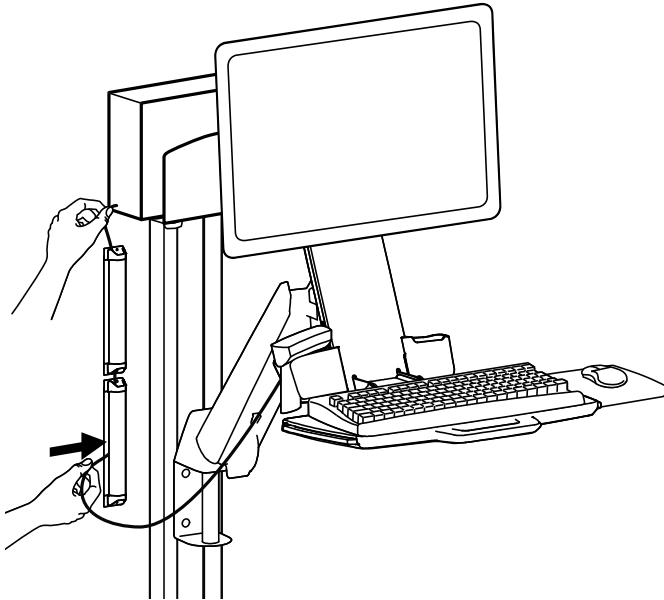

**k**

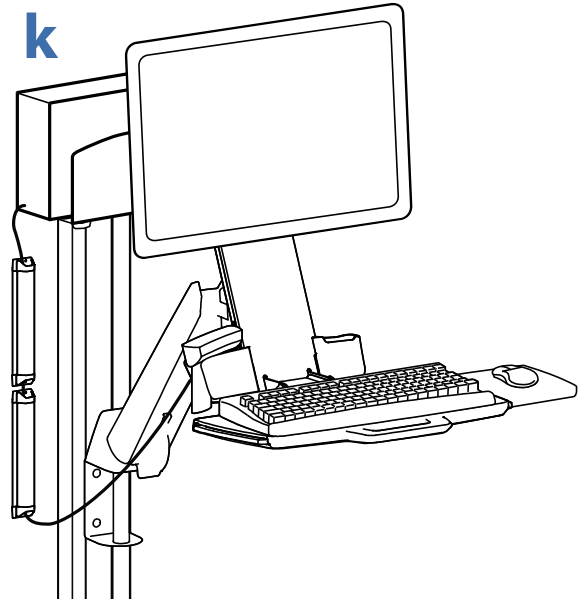

**14 a**

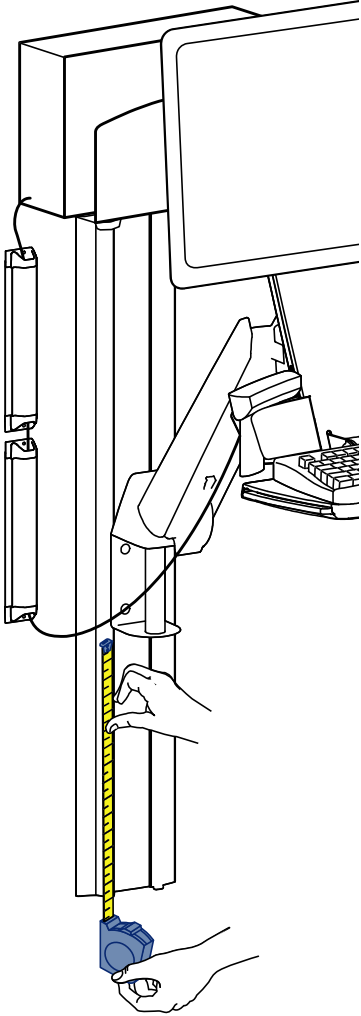

**b**

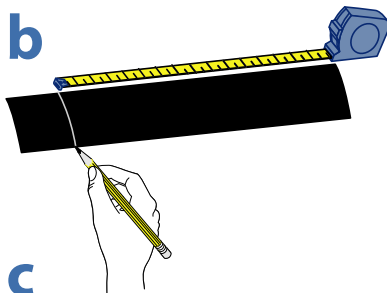

**c**

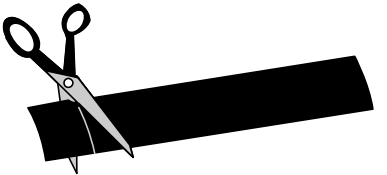

**d**

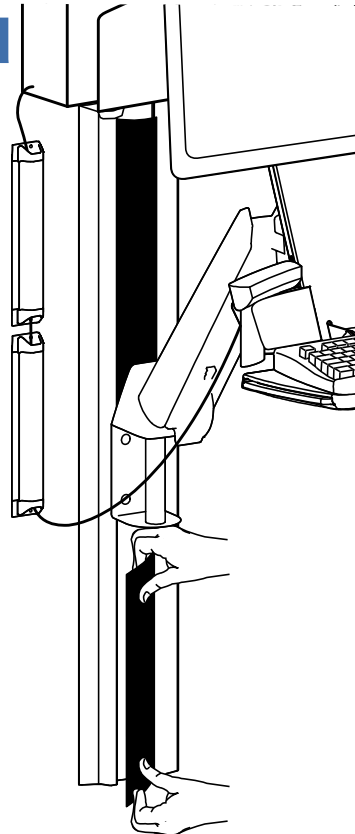

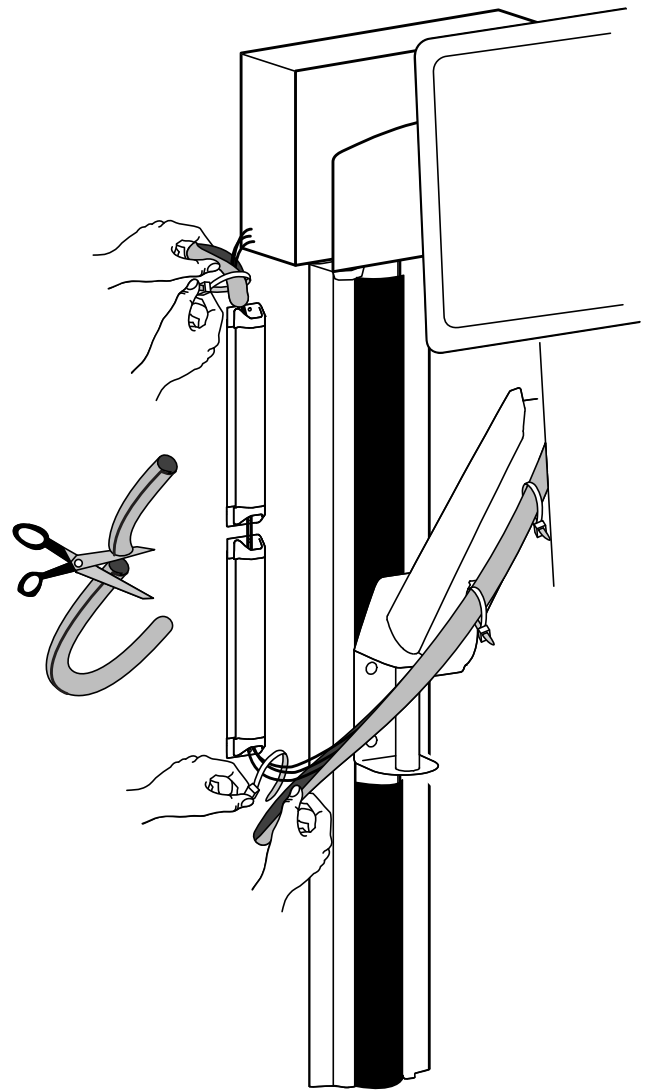
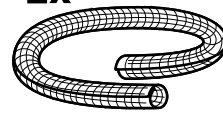

**15 2x**

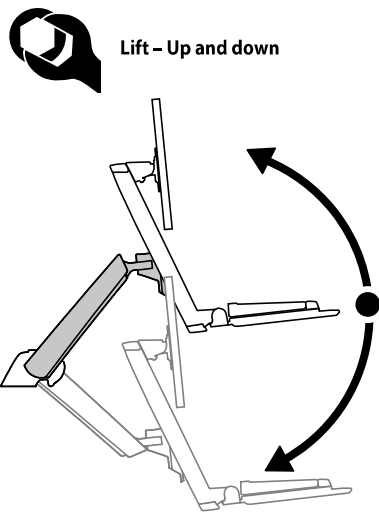

# 16 Adjustment Step

Important! You will need to adjust this product after installation is complete. Make sure all your equipment is properly installed on the product before attempting adjustments. This product should move smoothly and easily through the full range of motion and stay where you set it. If movements are too easy or difficult or if product does not stay in desired positions, follow the adjustment instructions to create smooth and easy movements. Depending on your product and the adjustment, it may take many turns to notice a difference. Any time equipment is added or removed from this product, resulting in a change in the weight of the mounted load, you should repeat these adjustment steps to ensure safe and optimum operation.



**+**  **LB kg** Increase Lift Strength  
If the mounted weight is too heavy or this product does not stay up when raised, then you'll need to increase Lift Strength:

**-**  **LB kg** Decrease Lift Strength  
If the mounted weight is too light or this product does not stay down when lowered, then you'll need to decrease Lift Strength:

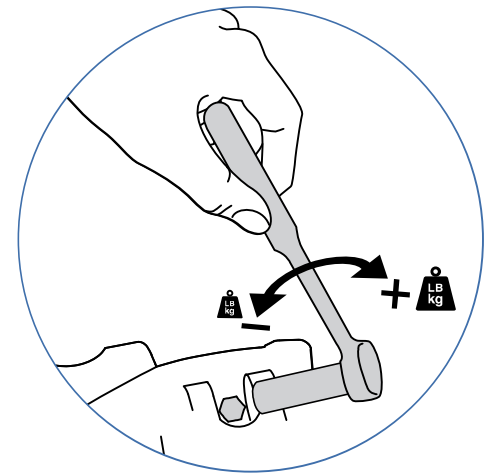
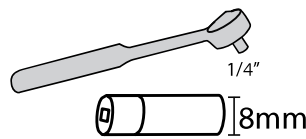
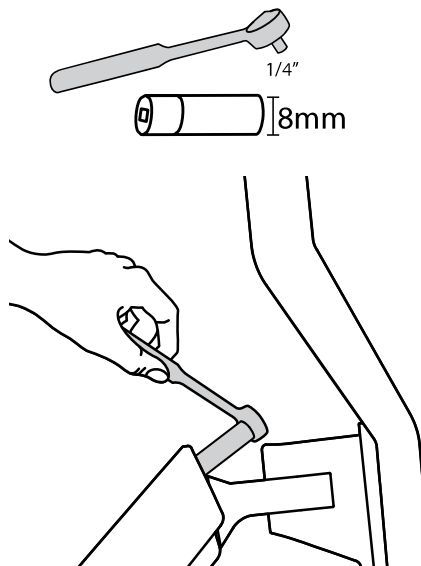



**Lift – Up and down**

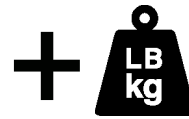
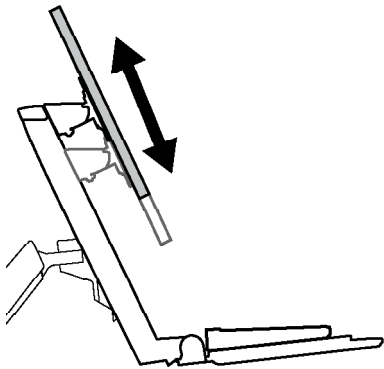

**Increase Lift Strength**

If the mounted weight is too heavy or this product does not stay up when raised, then you'll need to increase Lift Strength:



**Decrease Lift Strength**

If the mounted weight is too light or this product does not stay down when lowered, then you'll need to decrease Lift Strength:

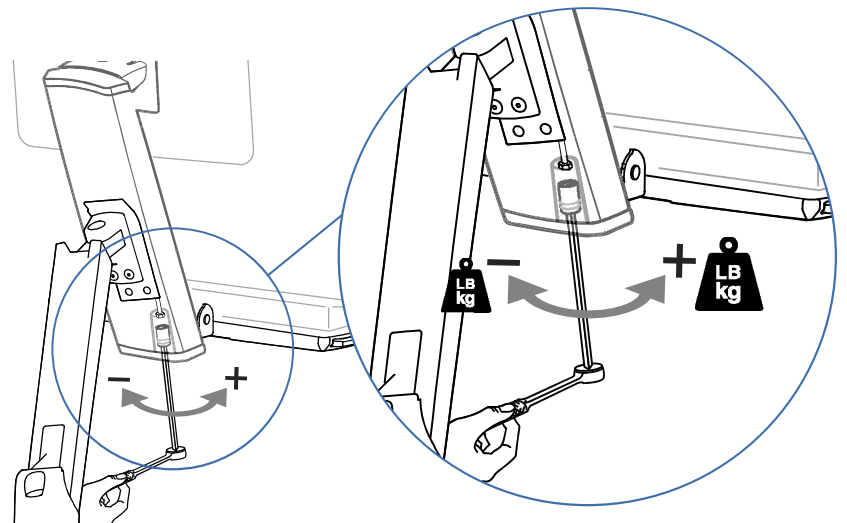
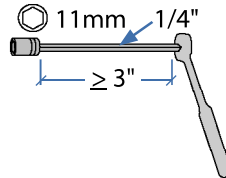

**Tilt – Forward and Backward**

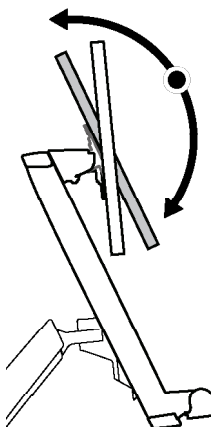

**Increase Friction**

If this product moves too easily, then you'll need to increase friction:



**Decrease Friction**

If this product is too difficult to move, then you'll need to decrease friction:

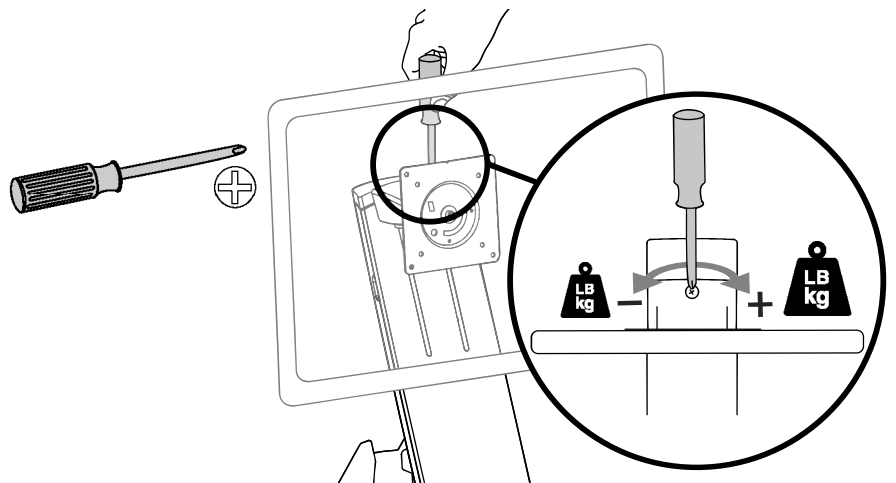



### Arm Swing – Side-to-side

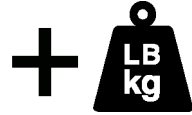
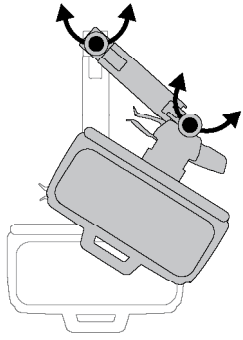

### Increase Friction

If this product moves too easily, then you'll need to increase friction:



### Decrease Friction

If this product is too difficult to move, then you'll need to decrease friction:

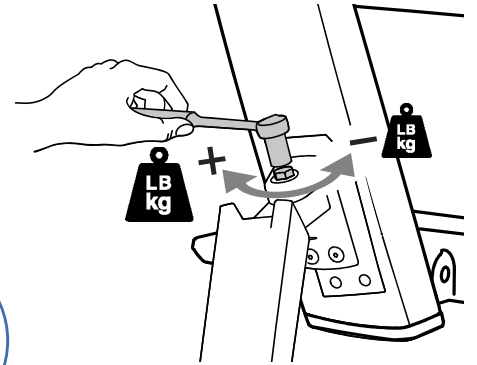
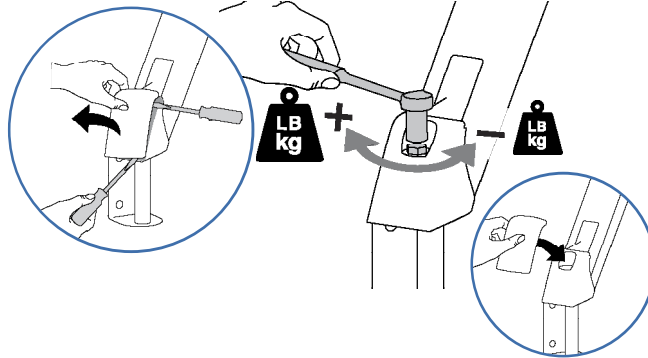

### Keyboard Storage

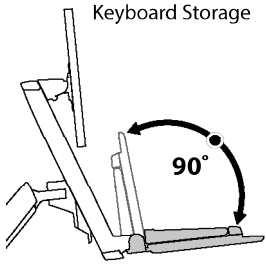

### Keyboard Use

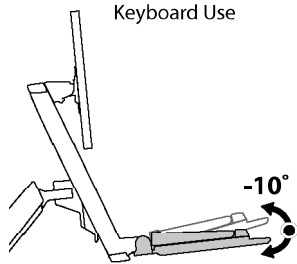

### Set Keyboard Angle to -10 degrees

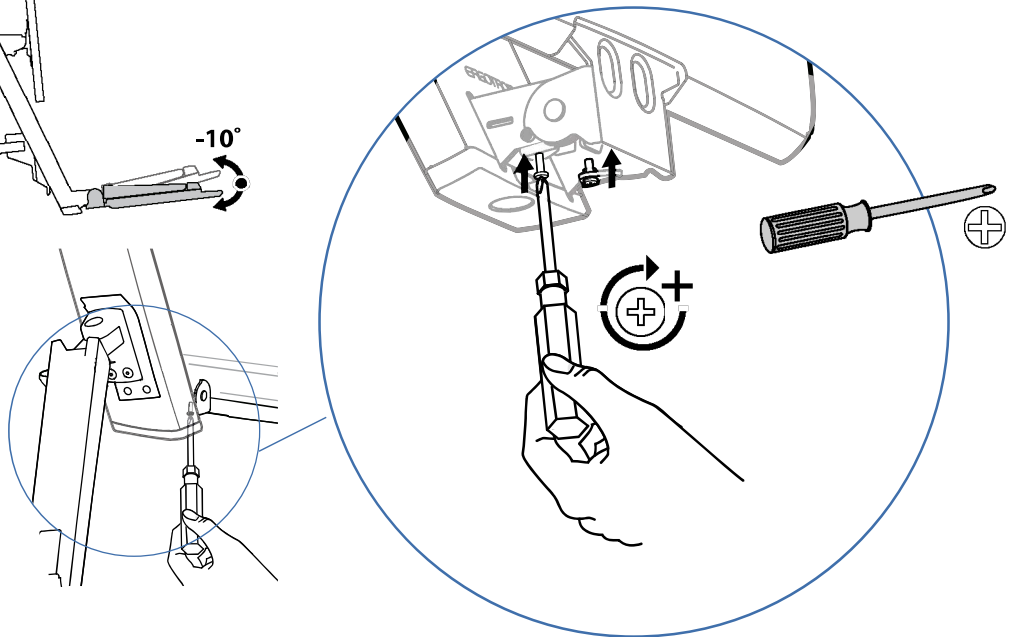

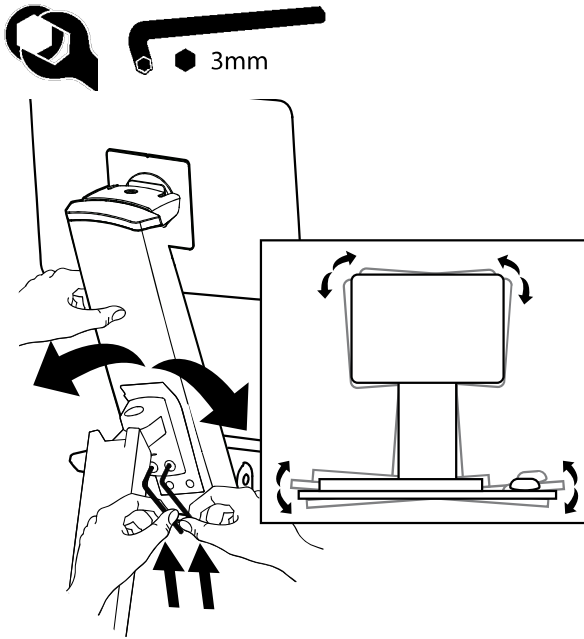

## Set Your Workstation to Work For YOU!

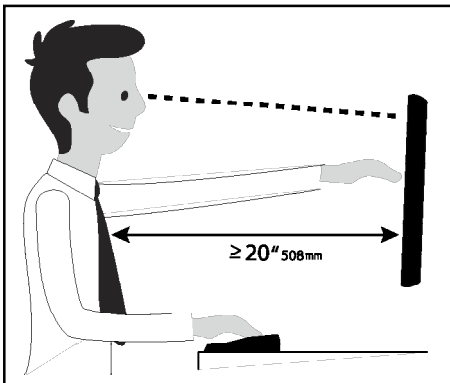

Learn more about ergonomic computer use at:  
[www.computingcomfort.org](http://www.computingcomfort.org)

- Height** Position top of screen slightly below eye level.  
**Position keyboard at about elbow height with wrists flat.**
- Distance** Position screen an arm's length from face—at least 20" (508mm).  
**Position keyboard close enough to create a 90° angle in elbow.**
- Angle** Tilt screen to eliminate glare.  
**Tilt the keyboard back 10° so that your wrists remain flat.**

**To Reduce Fatigue**  
**Breathe - Breathe deeply through your nose.**  
**Blink - Blink often to avoid dry eyes.**  
**Break • 2 to 3 minutes every 20 minutes**  
**• 15 to 20 minutes every 2 hours.**

# ergotron®

www.ergotron.com | USA: 1-800-888-8458 | Europe: +31 (0)33-45 45 600 | China: 400-120-3051 | Japan: japansupport@ergotron.com

© 2014 Ergotron, Inc. All rights reserved.

While Ergotron, Inc. makes every effort to provide accurate and complete information on the installation and use of its products, it will not be held liable for any editorial errors or omissions (including those made in the process of translation from English to another language), or for incidental, special or consequential damages of any nature resulting from furnishing this instruction and performance of equipment in connection with this instruction. Ergotron, Inc. reserves the right to make changes in the product design and/or product documentation without notification to its users. For the most current product information, or to know if this document is available in languages other than those herein, please contact Ergotron. No part of this publication may be reproduced, stored in a retrieval system, or transmitted in any form or by any means, electronic, mechanical, photocopying, recording or otherwise without the prior written consent of Ergotron, Inc., 1181 Trapp Road, Eagan, Minnesota, 55121, USA. Patents Pending and Patented U.S. & Foreign. Ergotron is a registered trademark of Ergotron, Inc.